



ELECTRONICS, INC.
 44 FARRAND STREET
 BLOOMFIELD, NJ 07003
 (973) 748-5089
<http://www.nteinc.com>

NTE942 Integrated Circuit Low Noise, Dual Preamp

Description:

The NTE942 is a dual preamplifier for the amplification of low level signals in applications requiring optimum noise performance. Each of the two amplifiers is completely independent, with individual internal power supply decoupler-regulator, providing 120dB supply rejection and 60dB channel separation. Other outstanding features include high gain (112dB), large output voltage swing ($V_{CC} - 2V_{p-p}$), and wide power bandwidth (75kHz, $20V_{p-p}$). The NTE942 operates from a single supply across the wide range of 9 to 40V.

Either differential input or single ended input configurations may be selected. The amplifier is internally compensated with the provision for additional external compensation for narrow band applications.

Features:

- Low Noise: $.5\mu V$ Total Input Noise
- High Gain: 112dB Open Loop
- Single Supply Operation
- Wide Supply Range: 9-40V
- Power Supply Rejection: 120dB
- Large Output Voltage Swing ($V_{CC} - 2V_{P-P}$)
- Wide Bandwidth 15MHz Unity Gain
- Power Bandwidth 75kHz, $20V_{P-P}$
- Internally Compensated
- Short Circuit Protected

Absolute Maximum Ratings:

Supply Voltage	+40V
Power Dissipation (Note 1)	715mW
Operating Temperature Range	0°C to +70°C
Storage Temperature Range	-65°C to +150°C
Lead Temperature (During Soldering, 10 sec max.)	+300°C

Note 1. For operation in ambient temperatures above +25°C, the device must be derated based on +150°C maximum junction temperature and a thermal resistance of 175°C/W junction to ambient.

Electrical Characteristics: ($T_A = +25^\circ\text{C}$, $V_{CC} = 14\text{V}$, unless otherwise specified)

Parameter	Test Conditions	Min	Typ	Max	Unit
Voltage Gain	Open Loop (Differential Input), $f = 100\text{Hz}$	160,000			V/V
Supply Current	$V_{CC} = 9\text{V to } 40\text{V}$, $R_L = \infty$	-	10	-	mA
Input Resistance Positive Input		-	100	-	k Ω
Negative Input		-	200	-	k Ω
Input Current, Negative Input		-	0.5	-	μA
Output Resistance	Open Loop	-	150	-	Ω
Output Current Source		-	8	-	mA
Sink		-	2	-	mA
Output Voltage Swing	Peak-to-Peak	-	$V_{CC}-2$	-	V
Unity Gain Bandwidth		-	15	-	MHz
Power Bandwidth	$20V_{P-P}$ ($V_{CC} = 24\text{V}$)	-	75	-	kHz
Maximum Input Voltage	Linear Operation	-	-	300	mV _{rms}
Supply Rejection ratio	$f = 1\text{kHz}$	-	60	-	dB
Channel Separation	$f = 1\text{kHz}$	-	60	-	dB
Total Harmonic Distortion	60dB Gain, $f = 1\text{kHz}$	-	0.1	-	%
Total Equivalent Input Noise	$R_S = 600\Omega$, 10 – 10,000Hz, (Single Ended Input, Flat Gain Circuit, $A_V = 1000$)	-	0.5	0.7	μV_{rms}

Pin Connection Diagram

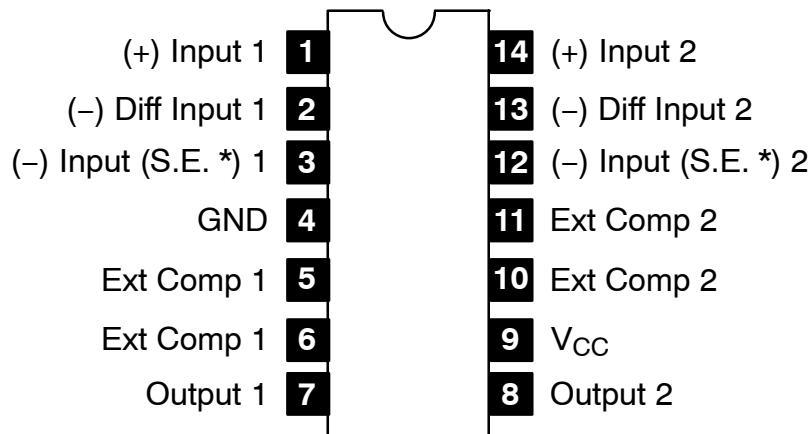

*NOTE: Single Ended

