



ELECTRONICS, INC.
 44 FARRAND STREET
 BLOOMFIELD, NJ 07003
 (973) 748-5089
<http://www.nteinc.com>

NTE7064 Integrated Circuit Bridge Driver for DC Motor Control

Description:

The NTE7064 is an integrated circuit in a 7-Lead SIP type package designed for use as a bridge driver for brushed DC motor rotation control. Forward rotation, reverse rotation, stop, and braking operations are available. Typical applications include a loading and reel motor driver for VCR and tape deck, and any other consumer and industrial applications.

Features:

- Output Current Up to: 1 Amp (Average), 3 Amp (Peak)
- 4 Function Modes (CW, CCW, STOP, and BRAKE) are Controlled by 2 Logic Signals Fed Into 2 Input Terminals
- Built-In Over Current Protection and Thermal Shut-Down Circuit
- Operating Voltage Range: $V_{CC} = 6V$ to $18V$

Absolute Maximum Ratings: ($T_A = +25^\circ C$ unless otherwise specified)

Supply Voltage, V_{CC}		
Peak	25V
Operating	18V
Output Current, I_O		
Average	1A
Operating	3A
Power Dissipation ($T_C = +75^\circ C$), P_D		12.5W
Operating Temperature Range, T_{opr}		-30° to $+75^\circ C$
Storage Temperature Range, T_{stg}		-55° to $+150^\circ C$

Electrical Characteristics: ($T_A = +25^\circ C$ unless otherwise specified)

Parameter	Symbol	Test Conditions	Min	Typ	Max	Unit
Supply Current	I_{CC1}	$V_{CC} = 18V$, Output OFF, Stop Mode	-	1.8	3.5	mA
	I_{CC2}	$V_{CC} = 18V$, Output OFF, CW/CCW Mode	-	8.3	12.0	mA
	I_{CC3}	$V_{CC} = 18V$, Brake Mode	-	8.5	13.0	mA

Electrical Characteristics (Cont'd): ($T_A = +25^\circ\text{C}$ unless otherwise specified)

Parameter	Symbol	Test Conditions	Min	Typ	Max	Unit	
Saturation Voltage	Upper	V_{S1U}	$V_{CC} = 18\text{V}, I_O = 100\text{mA}$	-	-	1.1	V
	Lower	V_{S1L}		-	-	1.0	V
	Upper	V_{S2U}	$V_{CC} = 18\text{V}, I_O = 1\text{A}$	-	1.2	1.5	V
	Lower	V_{S2L}		-	1.05	1.4	V
Output Transistor Leakage Current	Upper	I_{LU}	$V = 25\text{V}$	-	-	50	μA
	Lower	I_{LL}		-	-	50	μA
Input Voltage	IN 1	$V_{IN(H)}$	$T_J = +25^\circ\text{C}, \text{Pin1 and Pin2}$	3.0	-	-	V
	IN 2	$V_{IN(L)}$		-	-	0.8	V
Diode Forward Voltage	Upper	V_{FU}	$I_F = 1\text{A}$	-	2.0	-	V
	Lower	V_{FL}		-	1.3	-	V
Limiting Current	I_{SC}		-	2.5	-	A	
Input Current 1, 2	$I_{IN,1,2}$	$T_J = +25^\circ\text{C}, \text{Pin1 and Pin2}$	-	1	30	μA	

Block Diagram

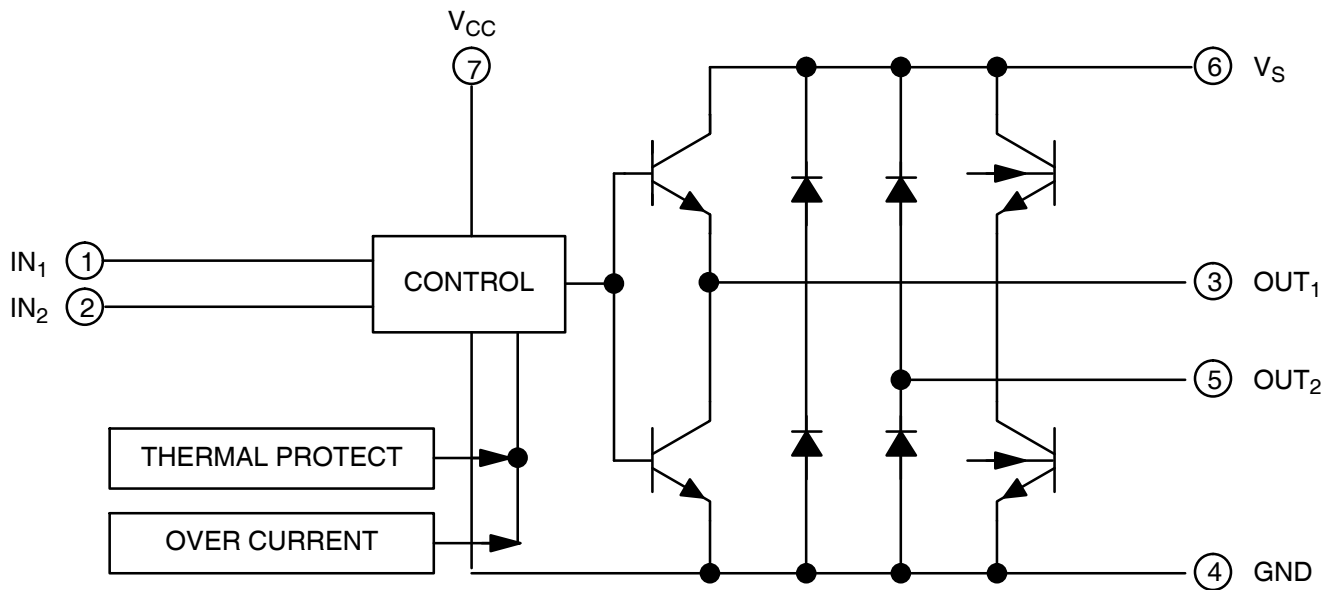

IN 1	IN 2	OUT 1	OUT 2	MODE
1	1	L	L	Brake
0	1	L	H	CW/CCW
1	0	H	L	CCW/CW
0	0	High Impedance		Stop

Pin Connection Diagram (Front View)

